

AT 200 ALUMINIUM ENTRANCE DOOR

AT200 OPTIONS: SQUARE-EDGED OR PROFILED OUTSIDE OR INSIDE



Outside view



Inside view

Thermal insulation
(in W/m^2K)



U_D as low as 1.2

Sound reduction
(in dB)



up to 40

Security



up to RC 2

Design style

home pure

home soft

ambiente

Characteristics

- Exposed door hinges

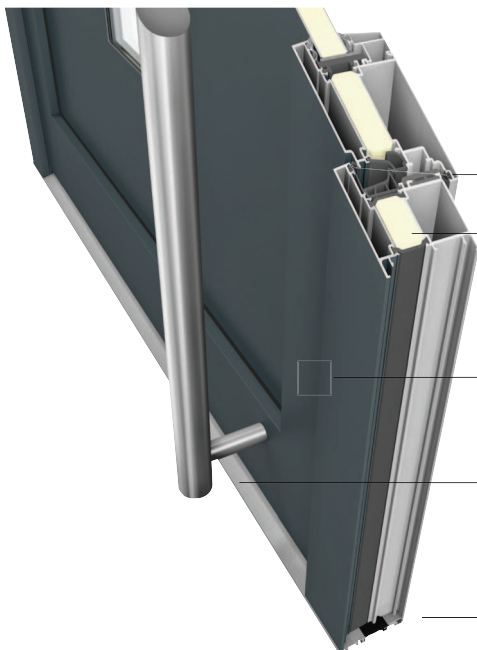

3 gasket levels

3-chamber frame profile and foam insulation core for very high thermal insulation

Square-edged or profiled design inside and outside

Low threshold thermally broken

Construction depth 80 mm

Sections

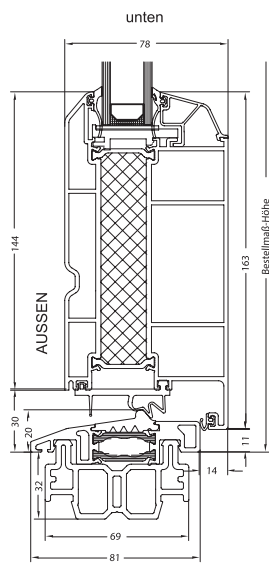
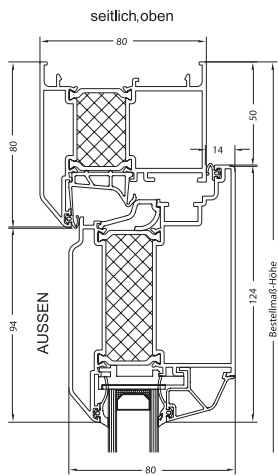

Isotherm

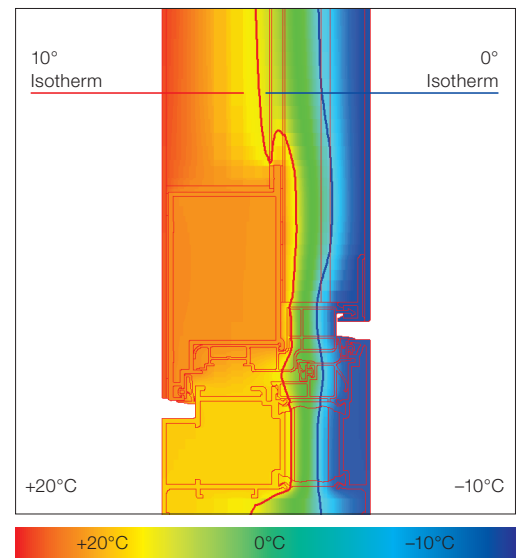

Door models



AT200-17-061



AT200-17-065



AT200-17-068



AT200-17-075



AT200-17-077



AT200-17-087



AT200-17-088



AT200-17-089

Internorm Window UK

01/17