

# AT 400 ALUMINIUM ENTRANCE DOOR

## AT400 SQUARE-EDGED OUTSIDE AND INSIDE



Outside view



Inside view

**Thermal insulation**  
(in  $W/m^2K$ )



$U_D$  as low as 0.75

**Sound reduction**  
(in dB)



up to 36

**Security**



up to RC 2

**Design style**

home pure

home soft

ambiente

**Characteristics**

- Concealed door hinges (optional)

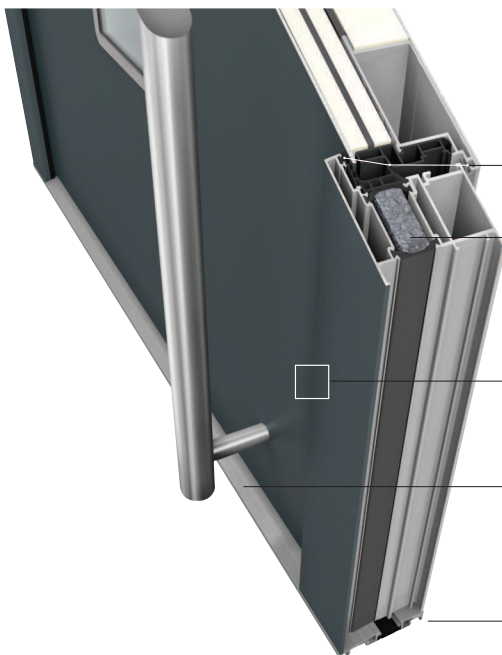

3 gasket levels

3-chamber frame profile and foam insulation core for very high thermal insulation

Square-edged design inside and outside

Low threshold thermally broken

Construction depth 93 mm

# ALUMINIUM ENTRANCE DOOR AT 400

## Sections

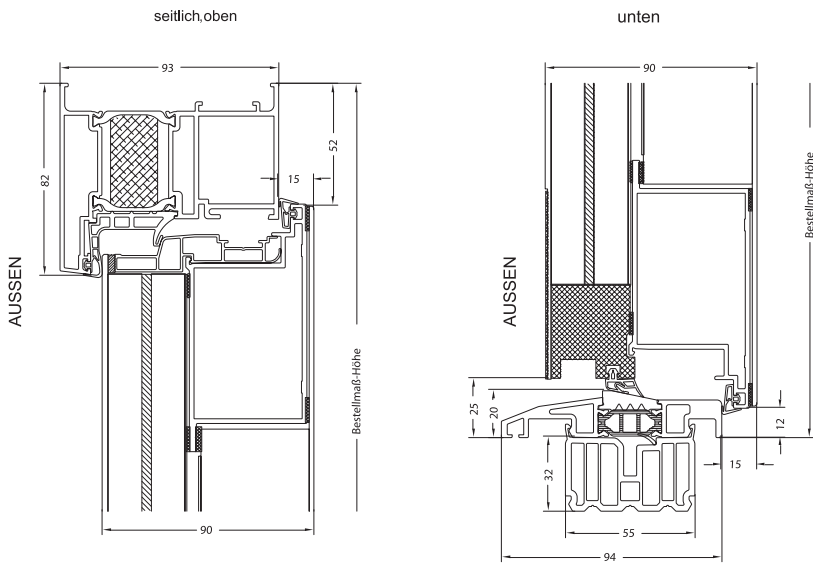

## Isotherm

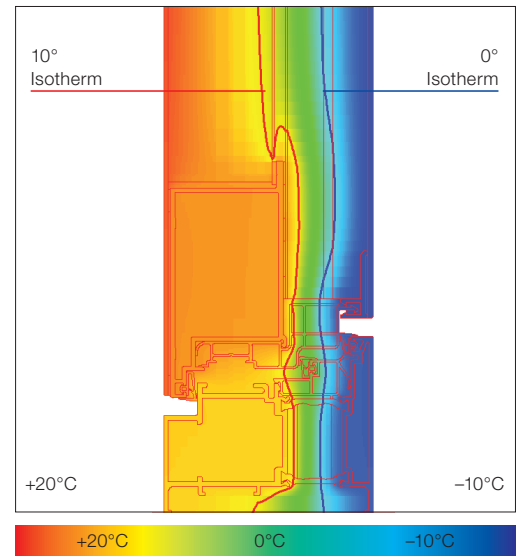

## Door models



AT400-17-005



AT400-17-006



AT400-17-027



AT400-17-029



AT400-17-036



AT400-17-044



AT400-17-045



AT400-17-046



AT400-17-047

Internorm Window UK

01/17



✉ [quote@altitudealuminium.co.uk](mailto:quote@altitudealuminium.co.uk)

☎ 01244 529199